

# Solar Based Home Audio System

**D.Sathiyaraj, K.Prashanth,**  
Assistant Professor's, Dept. of EEE  
Sengunthar Engineering College (Autonomous),  
TamilNadu, India

**V.Kavin,M.Kavin,R. Sanjay**  
UG Students, Dept of Electrical and Electronics Engineering,  
Sengunthar Engineering College (Autonomous),  
TamilNadu, India

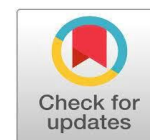

## Publication History:

Manuscript Reference No: IJIRIS/RS/Vol.11/Issue02/APIS10095

Research Article | Open Access | Double-Blind Peer-Reviewed | Article ID: IJIRIS/RS/Vol.11/Issue02/APIS10095

Received: 02, April 2025 Revised: 14, April 2025 Accepted: 25, April 2025 Published Online: 05, May 2025, Volume 2025

Article ID APIS10093 <https://www.ijiris.com/volumes/Vol11/iss-02/16.APIS10095.pdf>

**Article Citation: Sathiyaraj, Prashanth, Kavin, Kavin, Sanjay (2025).** Solar Based Home Audio System: IJIRIS: International Journal of Innovative Research in Information Security, Volume 11, Issue 02, Pages 164-168

doi-> <https://doi.org/10.26562/ijiris.2025.v1102.16>

**BibTex key: Sathiyaraj@2025Solar**



Copyright: ©2025 This is an open access article distributed under the terms of the Creative Commons Attribution License; which Permits unrestricted use, distribution, and reproduction in any medium, provided the original author and source are credited.

**Abstract** An innovative solution that combines solar energy with home entertainment systems, the Smart Solar-Based Home Audio System with MPPT (Maximum Power Point Tracking) Controller aims to provide an energy-efficient and environmentally responsible alternative for powering audio devices. An MPPT controller optimises the solar energy captured by a solar panel in this system to guarantee the highest possible energy output, even in the presence of fluctuating sunshine. The audio system is powered by a battery that stores the energy. By adjusting to variations in solar irradiation and load demands, the incorporation of MPPT technology guarantees that the solar panels run as efficiently as possible. Wireless control adds to the system's intelligence by enabling users to remotely monitor solar power generation and adjust audio settings via a smartphone app or smart device. By using renewable energy for entertainment, this method not only lessens dependency on grid electricity but also promotes sustainability. Furthermore, the system is a great option for off-grid applications or locations with restricted access to traditional power sources due to its low power consumption and effective energy conversion. The user interface, audio playback, and power distribution are all controlled by a microcontroller-based system. Features of the system include voice command activation, remote control, and adjustable audio settings. Results from experiments show how well the MPPT controller maximises power output and how the system as a whole can play high-quality music while using the least amount of energy.

**Keywords:** Renewable Energy, Solar Panels, Energy Efficiency.

## INTRODUCTION

Renewable energy sources like solar electricity are becoming more popular as a result of the growing global energy issue and environmental concerns. In order to maximise power extraction from solar panels, the smart solar-powered home audio system presented in this study incorporates an MPPT controller. Even with fluctuating solar irradiation, an MPPT controller guarantees maximum power output. The brain of the operation is a microcontroller-based system that controls user interactions, music playback, and power distribution. This clever technology offers a smooth and intuitive experience by enabling voice command activation, remote control, and adjustable audio settings. Energy independence, environmental friendliness, cost-effectiveness, and an improved user experience are only a few benefits of the suggested system. The technology is perfect for off-grid or rural areas since it uses solar energy to lessen the need for grid electricity. A clean and renewable energy source, solar power helps create a more environmentally friendly future. The technology is a cost-effective alternative because it can eventually drastically lower electricity expenditures. The MPPT controller, microcontroller-based system, and audio components of the smart solar-powered home audio system will all be covered in detail in the upcoming parts. The performance and efficiency of the system will be validated through the presentation of experimental results.

## PROBLEM IDENTIFICATION

Solar energy depends on the availability of sunshine and is sporadic. Batteries and other efficient energy storage devices are essential for maintaining audio playback even in the absence of sunlight. For charging and discharging cycles to be optimised, proper battery management is necessary.

1. The total performance of the system is directly impacted by the MPPT controller's efficiency. Precise monitoring of the maximum power point is crucial, particularly in changing solar environments. Power extraction and tracking accuracy can be enhanced by sophisticated MPPT algorithms such as Perturb and Observe (P&O) and Incremental Conductance (INC).
2. Without sacrificing system speed, the microcontroller should have enough power to manage intricate operations like network communication, audio processing, and user interface interactions.

3. A microcontroller with sufficient memory and processing power is necessary for seamless operation and prompt user input response.
4. Achieving a balance between economical power usage and high-quality audio output is crucial for maximising battery life and system performance. Digital signal processing methods and effective audio amplifiers can assist in lowering power usage without sacrificing audio quality. Power-saving modes can also be used to further reduce energy consumption when not in use.

### PROPOSED SYSTEM

An extensive overview of a home audio system that runs on solar power is shown in the diagram. The main energy source, solar panels, transforms sunlight into direct current (DC) electricity. A DC-DC boost converter receives this DC power and raises the voltage to guarantee effective Li-ion battery charging. The MPPT controller is an essential part of the system. Even in situations with fluctuating solar irradiation, this controller dynamically modifies the solar panel's operating voltage to optimize power output. The system will be able to harvest as much energy from the sun as feasible thanks to this optimization. The PWM regulator takes over after the battery is fully charged, controlling the output voltage to a level appropriate for driving the audio amplifier. This avoids energy waste and guarantees effective performance even in low light. The suggested system offers an immersive audio experience while promoting sustainability by fusing energy efficiency with high-quality sound performance. The system offers consumers who want to enjoy high-quality audio without sacrificing environmental responsibility a clean, affordable, and renewable energy alternative to traditional home entertainment setups. In the end, the Smart Solar-Based Home Audio System opens the door to more intelligent and environmentally friendly home entertainment options. The speaker is then driven by the amplifier, resulting in a high-quality audio output. Energy independence, less dependency on grid power, cost-effectiveness, and environmental friendliness are just a few benefits of this solar-powered audio system. This system offers a sustainable and environmentally responsible way to enjoy music without sacrificing convenience or quality by using the sun's energy. The system can have a user interface, like a display or a mobile app, to improve the user experience. Users can keep an eye on system characteristics including music settings, solar power output, and battery level using this interface. Furthermore, remote control features can be included, allowing users to operate the system from any location. The system can offer a pleasant and user-friendly experience by incorporating cutting-edge technologies like automated power management and voice command recognition.

The equations governing the method of finding  $I_c$  and  $V_c$  are as under:

$$I_c = C \frac{\Delta V_{ch}}{t_{ch}} = C \frac{V_a - V_b}{t_{ch}}$$

$$V_c = \frac{\Delta V_{ch}}{2} + V_a = \frac{V_a - V_b}{2}$$

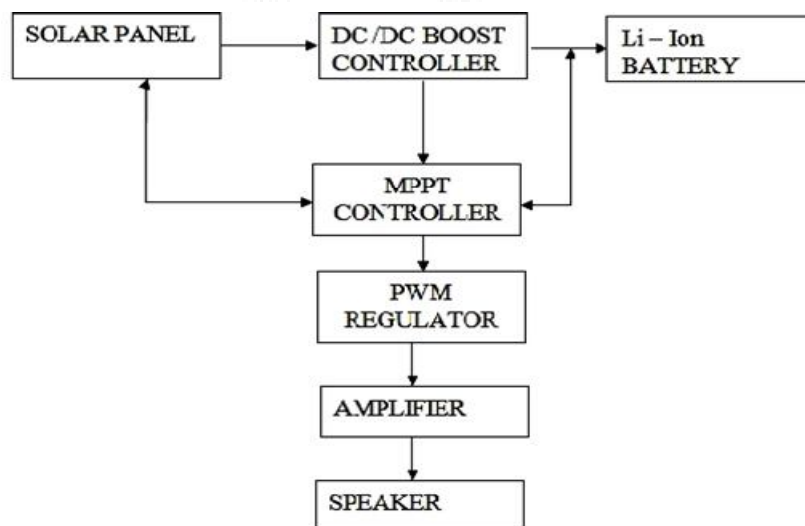

Fig 2- Block diagram for proposed system

### SIMULATION AND RESULT

The hardware prototype of the Smart Solar-Based Home Audio System was developed to validate the design and performance of the proposed model under practical conditions. The system consists of a 100 W, 12 V solar panel, a 12 V lithium-ion battery pack, a solar charge controller with MPPT feature, a DC-DC boost converter, an audio amplifier module, and wireless audio playback components. All components were integrated to ensure efficient energy flow and seamless operation during varying sunlight conditions.

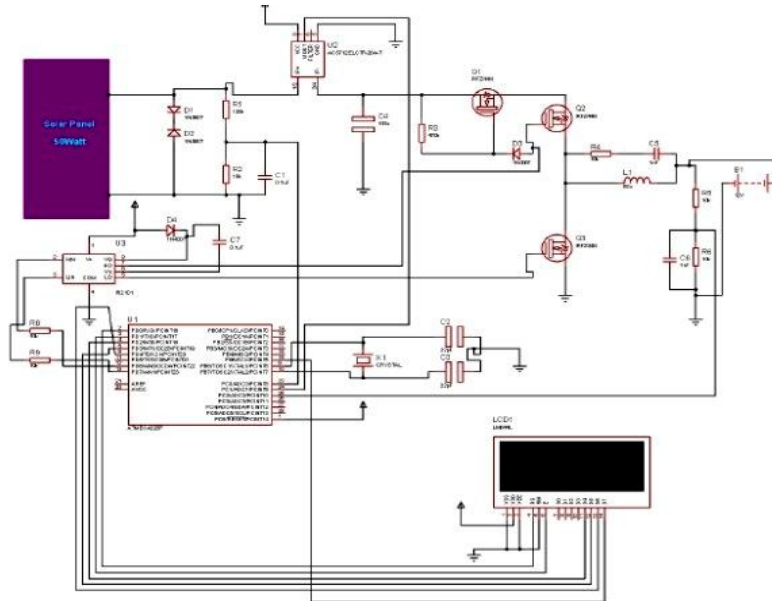

Fig 3 – Simulation Diagram

**HARDWARE OUTPUT**

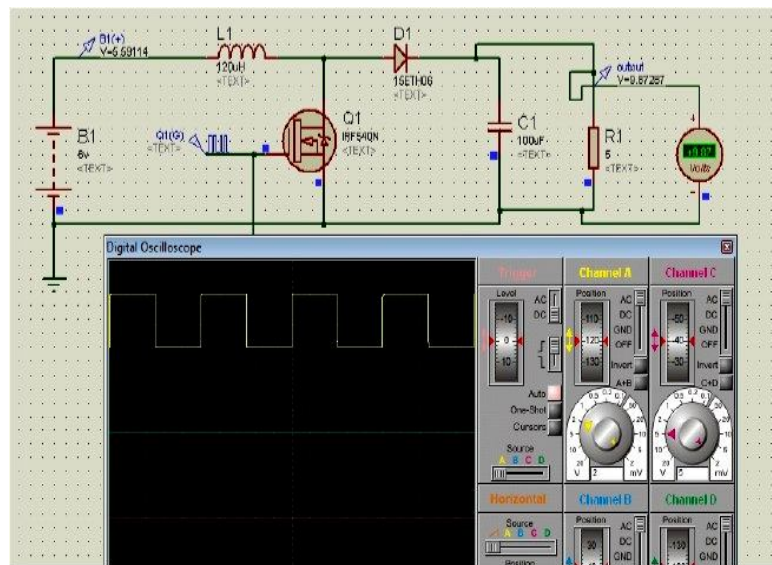

Fig 4 - Simulation Output of the boost converter

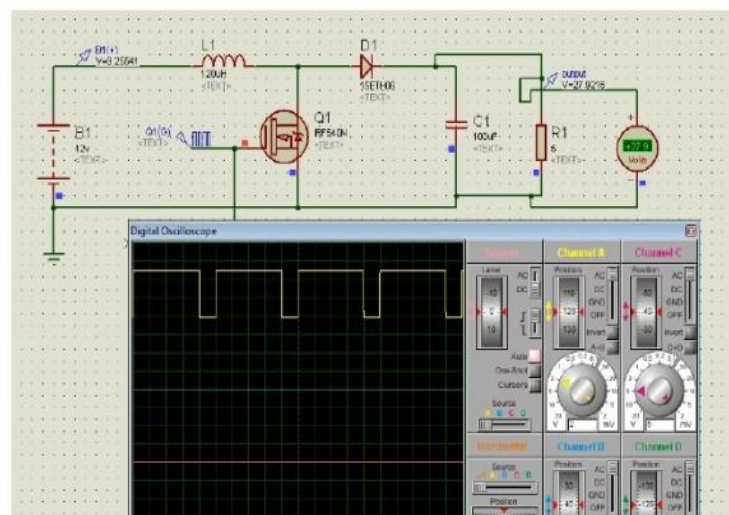

Fig 5- Boost converter input, output voltage, and the duty cycle



**Fig 6 - Audio System**

The solar panel serves as the primary energy source, converting solar radiation into electrical energy. The generated DC voltage is fed into the solar charge controller, which regulates the charging process of the lithium-ion battery and prevents issues such as overcharging, over-discharging, and reverse current flow. The charge controller used in this setup is capable of monitoring the panel voltage and current, as shown in Figure [insert your image reference here], which displays an operating voltage of 15.1 V under full sunlight.



**Fig 7- 100 W, 12 V solar panel**

The Maximum Power Point Tracking (MPPT) algorithm incorporated within the charge controller optimizes the output power by dynamically adjusting the operating voltage of the solar panel. This ensures that maximum energy is extracted even during fluctuating sunlight conditions. The regulated DC power from the charge controller is used both to charge the 12 V lithium-ion battery and to feed the DC-DC boost converter, which elevates the voltage to drive the audio amplifier efficiently.



**Fig 8 - Charge controller**

The audio amplifier powers the speaker system and is designed for low power consumption to ensure extended playback time even under limited sunlight. The battery acts as an energy backup, storing excess energy for continuous operation during nighttime or cloudy conditions. The entire system can also be monitored and controlled wirelessly through a microcontroller interface, which manages energy flow, battery status, and audio playback. During hardware testing, parameters such as solar voltage, current, battery charge level, and output power were observed. The system successfully delivered uninterrupted audio performance, demonstrating stable power regulation and efficient battery management. The prototype effectively proved that renewable solar energy could be utilized to power household entertainment systems with reliability and sustainability.

### CONCLUSION

A thorough design and execution of a smart solar-powered home audio system have been given in this study. Energy extraction from solar panels is optimised through the incorporation of a Maximum Power Point Tracking (MPPT) controller, guaranteeing effective operation even under conditions of fluctuating solar irradiation. The user experience is improved by the microcontroller-based system's sophisticated capabilities, which include voice command activation, remote control, and adjustable audio settings. The system is an eco-friendly and energy-independent option because it can capture solar energy and store it in a battery. It helps create a more sustainable future by lowering dependency on grid electricity. A top-notch listening experience is also offered by the system's sophisticated audio features and effective power management. More sophisticated MPPT algorithms, energy storage devices like fuel cells or super capacitors, and artificial intelligence methods for intelligent power management and audio optimization are some potential future research avenues. The potential of solar-powered audio systems can be further realised by tackling issues like battery degradation, power fluctuations, and audio quality under different conditions. The suggested smart solar-powered home audio system shows that incorporating renewable energy sources into daily applications is both feasible and advantageous. This system raises the bar for sustainable and excellent audio experiences by fusing cutting-edge technologies with practical design.

### REFERENCES

1. M.Shu,S.Wu,T.Wu,Z.Qia, Efficient energy consumption system using heuristic renewable demand energy optimization in smart city, *Comput. Intell.*, vol.38, no.3, pp. 784–800, 2022.
2. *Solar Photo Voltaic-Fundamentals, Technologies and Applications*”,ChetanSingh Solanki, PHI Learning Pvt. Ltd, 2022.
3. *Terrestrial Solar Photovoltaics*”,TapanK. Bhattacharya, London Narosa PublishingHouse,2021.
4. *Design of photovoltaic systems*”, Prof. Dr.L.Uman and, Department of Electronics System Engineering (DESE) of Indian Institute of Science, BangaloreApr,2021.
5. A.Bag,B.Subudhi,and P.K.Ray, A combined reinforcement learning and sliding mode control scheme for grid integration of a PV system, *CSEE J.Power Energy Syst.*, vol. 5, no. 4, pp. 498–506, 2019.
6. H.F.Feshara, A.M.Ibrahim, N. H. El-Amary, and S. M. Sharaf, Performance evaluation of variable structure controller based on sliding mode technique for a grid connected solar network, *IEEE Access*, vol. 7, pp. 84349–84359, 2019.
7. S.Revathi, N.Sivakumaran *Smart Solar Based Energy Systems for Remote Audio Applications IEEE Trans. Sustain. Energy*, vol. 4, no. 1, pp. 89–98, 2020.
8. IF Saharun,NSaudin, MA Mohamed, N Jamel *Smart Solar-Based Energy Systems for Remote Audio Applications Microprocess. Microsyst.*, vol. 77, p. 103124, 2020.
9. Sylvester Emeka Abonyi,Kingsley ChibuezeObute *Design and Implementation of a Solar- Powered Audio Amplification System Comput. Intell.*, vol. 38, no. 3, pp. 784–800, 2022.