

Pothole Detection & Monitoring System

Dr.Mahesh

Professor, Dept. of Computer Science and Engineering
Sri Sairam College of Engineering, Bengaluru, India
legacymahesh@gmail.com

<https://orcid.org/0000-0002-8738-1453>

Balaji K, Gowtham M, Hari Prasad, B Tarun

Dept. of Computer Science and Engineering
Sri Sairam College of Engineering, Bengaluru, India
sce23cs037@sairamtap.edu.in, sce23cs097@sairamtap.edu.in
sce23cs086@sairamtap.edu.in, sce23cs042@sairamtap.edu.in



Publication History

Manuscript Reference No: IJIRIS/RS/Vol.11/Issue09/NVIS10099

Research Article Open Access| Double-Blind Peer-Reviewed| Article ID: IJIRIS/RS/Vol.11/Issue09/NVIS10099 Received: 28, October 2025, Revised: 05, November 2025, Accepted: 12, November 2025, Published Online: 21, November 2025.

<https://www.ijiris.com/volumes/Vol11/iss-09/20.NVIS10099.pdf>

Citation: Dr.Mahesh, Balaji, Gowtham, Hari, Tarun (2025), Pothole Detection & Monitoring System, IJIRIS: International Journal of Innovative Research in Information Security, Volume 11, Issue 09 of 2025 pages 572-576

Doi: <https://doi.org/10.26562/ijiris.2025.v1109.20>

BibTeX Key: Dr.Mahesh@2025Pothole

IJIRIS papers should be cited as IJIRIS (International Journal of Innovative Research in Information Security, AM Publications, India 2025, ISSN 2349-7017, <https://doi.org/10.26562/ijiris.2025.v1109.20> The journal's official abbreviation is IJIRIS. Orcid: <https://orcid.org/0009-0004-9398-7488>

Copyright © 2025 copyright by the authors. This article is an open access article distributed under the terms and conditions of the Creative Commons Attribution (CC BY) license (<https://creativecommons.org/licenses/by/4.0/>).

Abstract: One of the major problems faced by developing countries is the maintenance of road condition. Road infrastructure for the society is very important because majority of road accidents takes place due to bad condition of road like potholes. Potholes are caused due to poor quality and badly maintained roads. The constant movement of the overweight vehicles like trucks is also responsible for these ill roads. This ill quality roads will cause severe damage to the vehicles in terms of tyre and most important thing is the accidents which are caused due to this. An optimal system should be developed to monitor the road condition and analyses for future work. We propose an innovative method to prevent these hazards by using the advanced sensor system. The sensors will be attached to vehicles and from vehicles, the data is obtained from sensors and the location obtained by the GPS are transferred to road transport authority by IOT where officials take necessary actions. This system consists of sensors like ultrasonic sensor, vibration sensor and accelerometer sensor for detecting pothole and Wi-Fi module and GPS module and Microcontroller used for data collecting and sending that data to IOT platform Using the obtained data, more damaged area can be prioritized and damage control can be reduced.

Keywords: Ultrasonic sensor, IOT, WIFI and GPS module, sensors, Pothole.

I. INTRODUCTION

In India more than 2,000 people lost their lives in 2019 due to road accidents caused by potholes and more than 4,000 people were injured in over 4,800 road accidents, according to the latest data given by the government in Parliament [8]. Potholes also cause damage to the vehicle's suspension, wheels/rims, tires, and exhaust pipe [7]. To overcome this issue the project aims at identifying the potholes using an ultrasonic sensor which will collect the data about distance and displacement along with an ODB2 sensor which will collect data about the car all this data will be sent to the raspberry pi which will process the data and send it to the cloud which will be stored on Elasticsearch all the data and will be displayed on the map in real time using Kibana it will display all the damaged roads, show heatmap on that location. Roads here are narrow and congested with poor quality and is not maintained properly. This road condition is a boosting factor for traffic congestion and number of road accidents. Potholes are formed due to heavy movements of vehicles and heavy rains and water logging. According to the survey of "road accidents in India 2020" there were 3,66,138 unfortunate incidences of road accidents during 2020 which claimed 1,31,714 lives and caused injuries to 3,48,279 persons. Pothole roads accounted for 15.2 per cent of the total road accidents in 2020 Over 3506 people killed by potholes last year. To overcome this pathetic condition many technologies have been implemented and integrated with road safety.

II. LITERATURE SURVEY

A. IoT Based Humps and Pothole Detection on Roads and Information Sharing

The proposed system is implemented using Arduino uno, Ultrasonic sensor and Accelerometer. This system uses the honey bee optimization algorithm (HBO). All sensed data is gathered to perform Pre-processing operation and then given to the honey bee optimization algorithm to monitor the surface of pavement.

The Kirchhoff's theory is applied for Realtime analysis and it has certain restrictions. To overcome this difficulty the system uses accelerometer included with ultrasonic sensor to sense, detect and measure the variation present in the signal and optimized using HBO technique. Arduino Uno is used in internet of things based on road monitoring system (IOT-RSM) for the flexibility of instructions while coding. The IOT RSM is used to update the status of the road with location information in cloud. [3]

B. Pothole Detection System using Artificial Intelligence

This paper describes a conceptual design of pothole detection using AI. The idea behind this system is to detect and notify the potholes possibly without the human intervention. This system is implemented using AI-enabled camera and the object detection API that will help to detect the potholes. The dataset is collected by cloning TensorFlow object detection repository from GitHub. The API is the open-source framework built on TensorFlow, making it easy to construct, train, and deploy objection detection models. The location of the vehicle is tracked using GPS and camera captures the image of the road continuously through Open CV, and the captured images then are compared with the trained data set of potholes. If the image matches with the dataset, then it sends an email to the municipal authorities along with the image and the location of the pothole. But the system lacks to provide the real-time pothole updates in google map. [5]

C. Detection of Potholes and Speed Breaker on Road

This paper provides the system consist of four units i.e. Microcontroller unit, mobile application unit, communication unit, cloud unit. Microcontroller unit collects all the information about the potholes, humps and speed breaker along with its geographical location. Communication unit provides internet connectivity and also collects co ordinates of the pothole and distributes the data to the other units. Cloud unit receive all the data which are sent from the microcontroller unit. Lastly, mobile application unit uses the data and gives information to the driver.[4]

D. Modern Pothole Detection technique using Deep Learning

This project is implemented using Deep Learning, Transfer Learning, Faster Region-based Convolutional Neural Network (F-RCNN), Tensor flow API, Accelerometer, and Inception-V2. Deep Learning is used to detect potholes early using image and video which can reduce the chances of an accident. TensorFlow's object detection API is used for processing the captured images to get the high accuracy of the potholes. Transfer Learning and Inception-V2 help to save time and improve performance.

III. EXISTING SYSTEMS

In developing countries, the pavement pothole is often detected manually by inspectors of the municipal corporation during periodic field surveys. Although this conventional method can help to acquire an accurate evaluation of potholes, it also features low productivity in both data collection and data processing. The reason is that one pavement inspector can only inspect less than 10 km per day. With a large number of road sections needed to be inspected routinely, the automation of the pothole detection becomes a pressing need for transportation agencies. The simplest method might be to collect photos of road damage and hazards taken by the participants and to upload them to a central server. However, this requires strong participation and interaction from the users as well as manual image analysis. We believe that an automated approach for detecting potholes with little or no human interaction is more promising. This would ensure more comprehensive survey data with fewer errors caused by human factors than generated by the mere enthusiasm of participants. Moreover, the productive pavement surveying process significantly leads to economic gain. It is because, if the rehabilitation process is performed timely, pavement restoration cost can be saved by up to 80%. [5]

• Drawbacks of Existing system:

1. No map access to potholes data
2. No centralized storage of data
3. It requires more workforce.
4. Manual inspection in large cities will be complicated.
5. It is more time consuming.

• Advancement in the system:

1. Universal access of pothole data through web browser
2. Vehicle maintenance prediction

IV. OBJECTIVES

1. Avoidance of accidents by showing real-time potholes prone routes.
2. Accurate location of potholes.
3. Mark routes with pothole density (similar to traffic density in Google map).
4. Provide vehicle maintenance information to the user.

V. PROPOSED SOLUTION

The proposed system is an IoT-based solution for detecting and monitoring potholes. It combines several sensors and wireless technologies to ensure high accuracy and real-time reporting. The system centers on the Arduino Nano, which connects with an ultrasonic sensor, an MPU6050 accelerometer-gyro module, and a vibration sensor to detect changes in road surface conditions. The ultrasonic sensor identifies sudden changes in distance when a vehicle goes over a depression. Meanwhile, the accelerometer and vibration sensor record impact forces and shifts in orientation. This setup allows for multi-sensor validation and reduces false detections from speed bumps or minor bumps.

When a pothole is detected, the GPS module (MV62) logs the exact location coordinates. This ensures precise mapping of the damaged road segment. The Wemos ESP8266 module then sends the pothole information, which includes depth, vibration intensity, sensor data, and GPS location, to a cloud platform via WiFi. This lets authorities monitor road conditions remotely. Additionally, the 16x2 LCD module provides real-time feedback, showing sensor readings and system status. The LM2596 power module keeps all components running smoothly. For mobile prototype testing, the L298 motor driver and DC motor manage movement, allowing the system to scan road surfaces on its own. The software is implemented using Arduino IDE with Embedded C. It handles sensor calibration, detection algorithms based on thresholds, noise filtering, GPS parsing, and wireless communication routines. Overall, this solution provides a strong, low-cost, and scalable method for automated pothole detection. It enables accurate identification, location tagging, and efficient monitoring to support timely road maintenance and enhance public safety.



VI. COMPONENT DESCRIPTION

HARDWARE

- MPU 6050 GY-521 3 Axis Gyro Accelerometer Sensor Module Arduino
- Ultrasonic Sensor (HC-SR04)
- Arduino Nano
- Wemos ESP 8266
- L298 Motor Driver Module
- Vibration Sensor
- JHD 162A 16x2 LCD panel
- GPS Receiver MV62
- LM2596 DC to DC
- DC Motor
- Bluetooth HC 05
- 12 v Power Supply

SOFTWARE

- Arduino software
- Embedded C

VII. ARCHITECTURE

Sensing Layer.

- An ultrasonic (HC-SR04) is used to measure the depth of a road surface.
- Adaptive motion control MPU6050 (Accel/Gyro) can detect shocks and changes in direction.
- Vibration sensor → impact confirmation.

Edge Control & UI Layer.

- Arduino Nano identifies all sensors, eliminates noise, and implements multi-sensor fusion thresholds.
- 16x2. JHD162A displays the live status (distance, vibration level), GPS lock and Wi-Fi state on an LCD screen.
- For testing purposes, the L298 motor driver and DC Motor (if on a rover) are controlled by Arduino.

Communication & Positioning Layer.

- The accuracy of the GPS MV62 at an approximate distance from the confirmed event to Arduino.
- ESP8266 (Wemos) provides Wi-Fi uplinking to the cloud via MQTT/HTTP.
- HC-05. Bluetooth (optional) for local debugging/calibration.

Power Layer.

- 12. V supply → LM2596. DC-DC regulators → stable 5. V/3.3. Nano, ESP8266, sensors, GPS and LCD V rails, L298...

Cloud & Services Layer.

- Ingestion API/Broker (MQTT/HTTP) receives telemetry.

- Events, coordinates, and sensor snapshots are stored in a Data Store (e.g. Firebase/ThingSpeak/DB)."
- Deciphering the consequences of pothole events, avoiding duplicated hits, and computing severity based on depth and vibration. Maintenance notifications and REST endpoint disclosure are included in the notification process.

Application Layer.

- The Web/Mobile dashboard provides access to a live map, event table, device health, and export/report information with GPS pins. Additionally, there are time tables for events.

ARCHITECTURE DIAGRAM

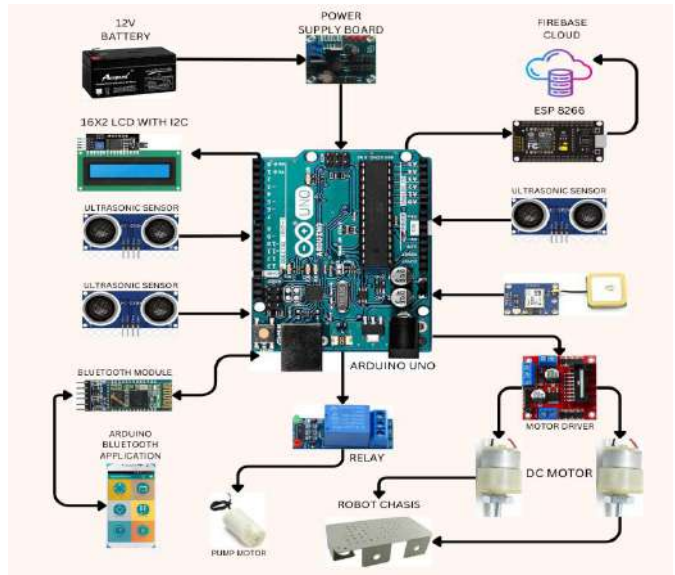
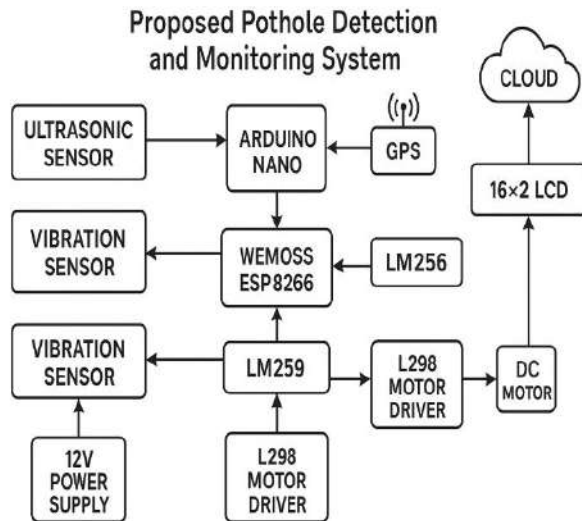

VIII. RESULTS AND OUTCOMES

A. Successful Multi-Sensor Pothole Detection.

By utilizing the combined input of an ultrasonic sensor, an MPU6050 accelerometer-gyro and a vibration sensor together, the system accurately identified potholes. Speed breakers, small bumps, or uneven surfaces were largely eliminated as false positives in the multi-sensor fusion technique. This is an important point to note. The system was able to distinguish between shallow depressions and real potholes by considering depth variation and the intensity of vibration.

B. Accurate Depth Measurement.

By using an ultrasonic sensor (HC-SR04), the system was able to measure pothole depth with accuracy, covering a range of 2 cm to 20+ cm. The measurements were presented on the 162 unit. Cloud processing logging and real-time LCD recording.

C. Real-Time Location Tracking.

GPS module (MV62) correctly determined the latitude and longitude of every pothole that was verified. Accurate mapping: Pothole locations on the dashboard were made possible by sending sensor data along with these coordinates.

D. Reliable Wireless Data Transmission.

With the ESP8266. The system's Wi-Fi module sent real-time pothole alerts and sensor values to the cloud. It also ensured stable communication within typical Wi-Fi coverage areas using HTTP/MQTT protocols. This enabled the monitoring of potholes from a distance by either users or authorities.

E. ON-DEVICE MONITORING & FEEDBACK.

The 16x2. The LCD display displayed continuous feedback, which included:

- Measured depth.
- Vibration level.
- GPS status.
- Wi-Fi status.
- Pothole detection alerts.
- Real-time observation, calibration and testing during movement were facilitated by this.

F. Autonomous Operation During Movement.

By mounting on a moving robotic platform (with DC motor and L298 driver), the system was able to automatically scan road surfaces and detect potholes while in motion. This proved the practicality of roadside scanning in deployment scenarios.epl).

G. Cloud Dashboard Visibility.

They used the cloud (Thing Speak/Firebase) to store and visualize the data they transmitted. The dashboard displayed:

- Real-time pothole alerts.
- Pothole depth readings.
- Vibration spikes.
- GPS markers on map.
- Time-stamped logs.
- A "live map" of road damage points was presented.

H. Cost-Effective and Scalable Solution.

Its general scheme was built using inexpensive components including the Arduino Nano, ESP8266, the MPU6050 and then the HC-SR04. The modular design makes it:

- Easy to upgrade (add camera/AI)
- Suitable for large-scale deployment.
- Affordable for municipal use.

I. Advanced Road Safety and Maintenance Planning.

The system enables:

- Early detection of dangerous potholes.
- Real-time reporting to authorities.
- Faster maintenance response.
- Reduced vehicle damage and accidents.
- This exhibits a considerable potential for smart-city infrastructure implementation.

IX. CONCLUSION

An efficient, automated, and affordable method for detecting and reporting potholes in real time is demonstrated by the IoT-Based Pothole Detection and Monitoring System. By utilizing ultrasonic sensing, vibration analysis, and accelerometer data, the system can detect potholes with precision and minimize false alarms. The integration of GPS guarantees precise location tracking, while the ESP8266 facilitates seamless wireless communication with cloud platforms for storage, visualization, and analysis. According to the project, IoT can significantly improve road maintenance by providing authorities with greater access to data at a faster pace, expedited reporting, and improved road safety and compliance. This approach not only improves road safety, but also prevents vehicle damage and accidents, making transportation safer. The system is scalable, practical, and ready for future developments, including the use of cameras for verification, machine learning analytics, or integration into smart city infrastructure.

REFERENCES

1. D.Purohit et al., "IoT-based pothole mapping agent with remote visualization," ResearchGate, 2022. Available: https://www.researchgate.net/publication/366789871_IoT-Based-Pothole-Mapping-Agent-with-Remote-Visualization
2. K.S.Narayana et al., "IoT-based pothole detection system using YOLO V4 algorithm," JNAO-NU, vol. 15, no. 1, 2024. https://jnao-nu.com/Vol.%2015%2C%20Issue.%2001%2C%20January-June%20%3A%202024/64_online.pdf
3. N.Gupta and A. Sharma, "IoT based speed breaker and pothole detection," IRJET, vol. 11, no. 4, Apr. 2024. <https://www.irjet.net/archives/V11/i4/IRJET-V11I4132.pdf>
4. P.Kumar and R. Verma, "Detection of pothole in real-time using Android based application," IRJET, vol. 8, no. 4, Apr. 2021. <https://www.irjet.net/archives/V8/i4/IRJET-V8I4573.pdf>
5. R.S.Reddy et al., "IoT based detection of pothole and hump using sensors," JES Publication, vol. 14, no. 6, pp. 512–519, 2023. <https://jespublication.com/uploads/2023-V14I6085.pdf>