

Smart Women Safety Camera System

Sathyaraj N 

Assistant Professor, Department of Robotics & Automation
Sengunthar Engineering College (Autonomous), Tiruchencode, India

nsatyarajra@secreg.co.in

<https://orcid.org/0009-0000-3437-5925>

Hannesh M, Sanjay S

Department of Robotics & Automation
Sengunthar Engineering College (Autonomous), Tiruchencode, India

haneeshmani2005@gmail.com, sanjaysanthosh0212@gmail.com



Publication History

Manuscript Reference No: IJIRIS/RS/Vol.12/Issue03/ISMR26.MRIS10100

Research Article Open Access| Double-Blind Peer-Reviewed| Article ID: IJIRIS/RS/Vol.12/Issue03/ISMR26.MRIS10100

Received: 31, January 2026, Revised: 14, February 2026, Accepted: 17, March 2026, Published Online: 25, March 2026.

<https://www.ijiris.com/volumes/Vol12/iss-03/21.ISMR26.MRIS10100.pdf> **BibTeX Key:** Sathyaraj@2026Smart

Article Citation: Sathyaraj, Hannesh, Sanjay (2026), Smart Women Safety Camera System, IJIRIS: International Journal of Innovative Research in Information Security, Volume 12, Issue 03 of 2026 pages 181-184

Doi: <https://doi.org/10.26562/ijiris.2026.v1203.21>

IJIRIS papers should be cited as IJIRIS (International Journal of Innovative Research in Information Security, AM Publications, India 2026, ISSN 2349-7017, <https://doi.org/10.26562/ijiris.2026.v1203.21> The journal's official abbreviation is IJIRIS. [Orcid: https://orcid.org/0009-0004-9398-7488](https://orcid.org/0009-0004-9398-7488) Copyright © 2026 copyright by the authors. This article is an open access article distributed under the terms and conditions of the Creative Commons Attribution (CC BY) license (<https://creativecommons.org/licenses/by/4.0/>).

Abstract: The Smart Women Safety Camera System is designed to enhance women's security using smart technology. It uses an ESP32-CAM to capture images during emergency situations. When danger is detected or a panic button is pressed, the system sends an alert message with the user's location to emergency contacts. The captured images are stored as evidence. This system is portable, low-cost, and helps provide quick response and improved personal safety.

INTRODUCTION

Women's safety is an important issue in today's society due to increasing cases of harassment and violence. Modern technology can help improve personal security through smart monitoring systems. The Smart Women Safety Camera System is designed to protect women by using technologies such as ESP32-CAM, IoT, and location tracking. In emergency situations, the system captures images and sends alert messages with the user's location to emergency contacts for quick help. This system is portable, affordable, and easy to use, providing real-time monitoring and fast response. It also helps collect visual evidence, making it useful for improving safety in public places, workplaces, and homes.

PROBLEM STATEMENT

Women often face safety risks such as harassment, stalking, and violence in public places, workplaces, and during travel. Many existing safety systems depend on manual help or delayed responses, which may not provide immediate protection in emergency situations. In many cases, there is also a lack of proper evidence and real-time location information to assist victims quickly. Therefore, there is a need for a smart and reliable system that can automatically detect unsafe situations, capture images as evidence, and send instant alerts with location details to emergency contacts to ensure faster response and improved women's safety.

PROPOSED IDEA

The proposed Smart Women Safety Camera System is designed to enhance women's security using smart and automated technology. The system uses an ESP32-CAM module to monitor surroundings and capture images during emergency situations. When the user presses an emergency button or a threat is detected, the camera captures photos and the system sends an alert message with the user's real-time location to predefined emergency contacts through a communication module. The captured images are stored as evidence for safety and investigation. This system is portable, low-cost, and easy to use, providing quick alerts and real-time monitoring to ensure better protection for women in public places, workplaces, and during travel.

SMART WOMEN SAFETY CAMERA SYSTEM AND USER NOTIFICATIONS

The Smart Women Safety Camera System is designed to provide protection and quick assistance during emergency situations. The system uses an ESP32-CAM module to capture images when a threat or unsafe situation occurs. When the user presses the emergency button, the system immediately sends notifications to predefined emergency contacts. These notifications include an alert message along with the user's real-time location. The captured images can also be stored and shared as evidence. This notification feature helps family members, friends, or authorities respond quickly and provide immediate support. By combining camera monitoring and instant alerts, the system improves women's safety and ensures faster communication during emergencies.

BLOCK DIAGRAM

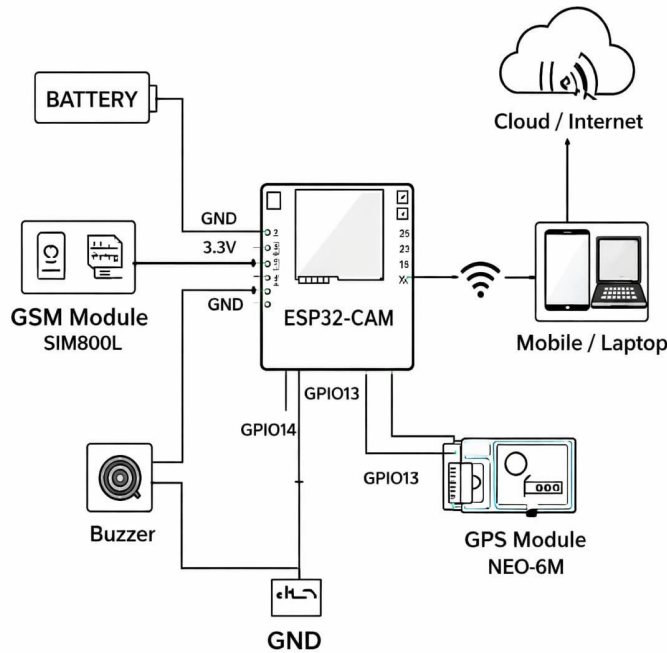

COMPONENTS USED:



ESP 32 CAM

The ESP32 plays a major role in the Smart Women Safety Camera System. It acts as the main controller that manages all the system operations. The ESP32-CAM module is used to capture images when an emergency situation occurs. When the user presses the panic button, the ESP32 activates the camera, captures the image, and processes the data. Using its built-in Wi-Fi capability, it can send alert notifications and the users location to predefined emergency contacts. The ESP32 is widely used because it is low-cost, energy-efficient, and supports IoT communication. This makes it suitable for real-time monitoring and quick response in women safety applications.



NEO-6M GPS

The NEO-6M GPS module is used in the Smart Women Safety Camera System to track the users real-time location. It receives signals from GPS satellites and determines the exact latitude and longitude of the user. During an emergency situation, the GPS module sends the location data to the ESP32 controller. The ESP32 then includes this location information in the alert message sent to emergency contacts. This helps family members or authorities quickly identify the users location and provide immediate assistance. The NEO-6M GPS module is widely used because it is accurate, reliable, and easy to interface with microcontrollers like ESP32.



BUZZER

A buzzer is used in the Smart Women Safety Camera System to provide an audible alert during emergency situations. When the user presses the panic button or when a threat is detected, the ESP32 activates the buzzer. The buzzer produces a loud sound to attract attention from nearby people and warn others about the emergency. This helps in alerting people around the user and can discourage potential attackers. The buzzer is simple, low-cost, and easy to connect with the ESP32, making it an effective safety alert component in the system.



BATTERY / POWER SUPPLY

The battery and power supply provide the required electrical energy to operate the Smart Women Safety Camera System. A rechargeable battery is used to power the ESP32-CAM, GPS module, buzzer, and other components. The power supply ensures stable voltage so that all modules work properly without interruption. Since the system is designed to be portable, a compact battery makes it easy to carry and use anywhere. A proper power management system also helps in longer battery life and reliable operation during emergency situations.



SIM800L GSM MODULE

The SIM800L GSM module is used to send alert messages in the Smart Women Safety Camera System. It works using a SIM card and mobile network. When an emergency occurs, the ESP32 sends a command to the SIM800L module.

REFERENCES

1. IEEE, "IoT Based Women Safety Device Using GPS and GSM," IEEE Conference on Communication and Electronics, Bangalore, India, 2020.
2. International Journal of Engineering Research & Technology, 'Design and Development of Women Safety Device Using IoT,' IJERT, Bhopal, Madhya Pradesh, India, 2021.
3. International Journal of Innovative Research in Science, Engineering and Technology, "Smart Women Safety System Using GPS and GSM," IJRSET, Chennai, Tamil Nadu, India, 2019.
4. Anna University, "IoT Based Women Safety Monitoring System," Engineering Project Report, Chennai, Tamil Nadu, India, 2022.
5. Indian Institute of Technology Delhi, "Women Safety Device Using Embedded System and IoT," Research Paper, New Delhi, India, 2021.